

**OCS – ORDNANCE CLEANING SYSTEM
Caliber 40 Field Cleaning Kit**

OCS-KIT-040F

USE AND MAINTENANCE MANUAL

Ordnance Cleaning Systems, LLC

7895 Division Drive

Mentor, OH 44060

Tel: (440) 205-0677

Fax: (440) 205-0678

ocs@ordclean.com

www.ordclean.com

Contents	Page
1. INTRODUCTION	3
1.1. Basic description of the System	3
1.2. Technical Features	3
1.3. System Overview	3
2. OPERATION	4
2.1. Assembly	4
2.2. Operating the System	6
2.3. Oiling the Barrel	7
2.4. Finish Cleaning with the Sleeve	7
3. COMPLETE CYLINDER ASSEMBLY/DISASSEMBLY	8
4. COMPLETE OILER ASSEMBLY/DISASSEMBLY	8
5. TOOL KIT	9
6. TROUBLESHOOTING	9
6.1. Air Leaks	9
6.2. Hose Connection	9
6.3. Control Box Assembly	10
6.4. Cylinder Assembly	10
6.5. Oil Dispenser	10
6.6. Cylinder Assembly (Does not move through the bore)	10
6.7. Cylinder Assembly (Does not clean the chamber properly)	11
7. STORAGE	11
8. ACRONYMS	11

1. INTRODUCTION

The following manual is a document that accompanies this system throughout its lifetime. It is, therefore, an integral part of the system. Carefully read the following instructions and procedures before engaging in any activity with this system. The following maintenance and instruction manual is an integral part of the system and must always be available to the personnel in charge of using and maintaining it. The operator and the personnel in charge of handling this system must have knowledge of the contents of the manual.

1.1 Basic description of system

The machine described in this manual is an Ordnance Cleaning System (OCS) which can be used for cleaning and oiling the bore of a 40mm weapon system.

SYSTEM WARNINGS*

-Make sure proper personal protection equipment is used during operation with the machine.

-Never start the vibrations before the brush is in the bore. When the cylinder is vibrating in the bore just a loose grip for a few seconds with a hand is allowed. No other contact of the vibrating parts with the human body is allowed.

-Use recommended oils and materials to insure system operates properly.

1.2 Technical Features

Weight	49 lbs
Max. Air supply pressure	145 psi
Air consumption	approximately 6-7 CFM at 90psi
Air inlet coupling	¼"
Vibrations	1500 – 2500 vibs/min (depends on air pressure & brush stiffness)

1.3 System Overview

The machine consists of 10 major components.

1. OCS-CBA-001 - Control Box (Complete)
2. OCS-CBSH-001 - Control Box Supply Hose
3. OCS-BRA-040 – Bore Rammer Assembly
4. OCS-CCK-040 – Centering Cone
5. OCS-CYL-040-057 - Cylinder Assembly
6. OCS-BBRA-040 (Bore Brush Abrasive x2); OCS-BBRN-040 (Bore Brush Nylon x2); OCS-BBRS-040 (Bore Brush Bronze x2)
7. OCS-OIL-030 – Oil Dispenser Assembly
8. OCS-TKA-001 – Tool Kit Assembly
9. OCS-CAS-003F – Pelican 1600 Case
10. OCS-LIN-040 – Linen Cloth (Not shown in diagram) x25

OCS-KIT-040F 40MM Field Kit

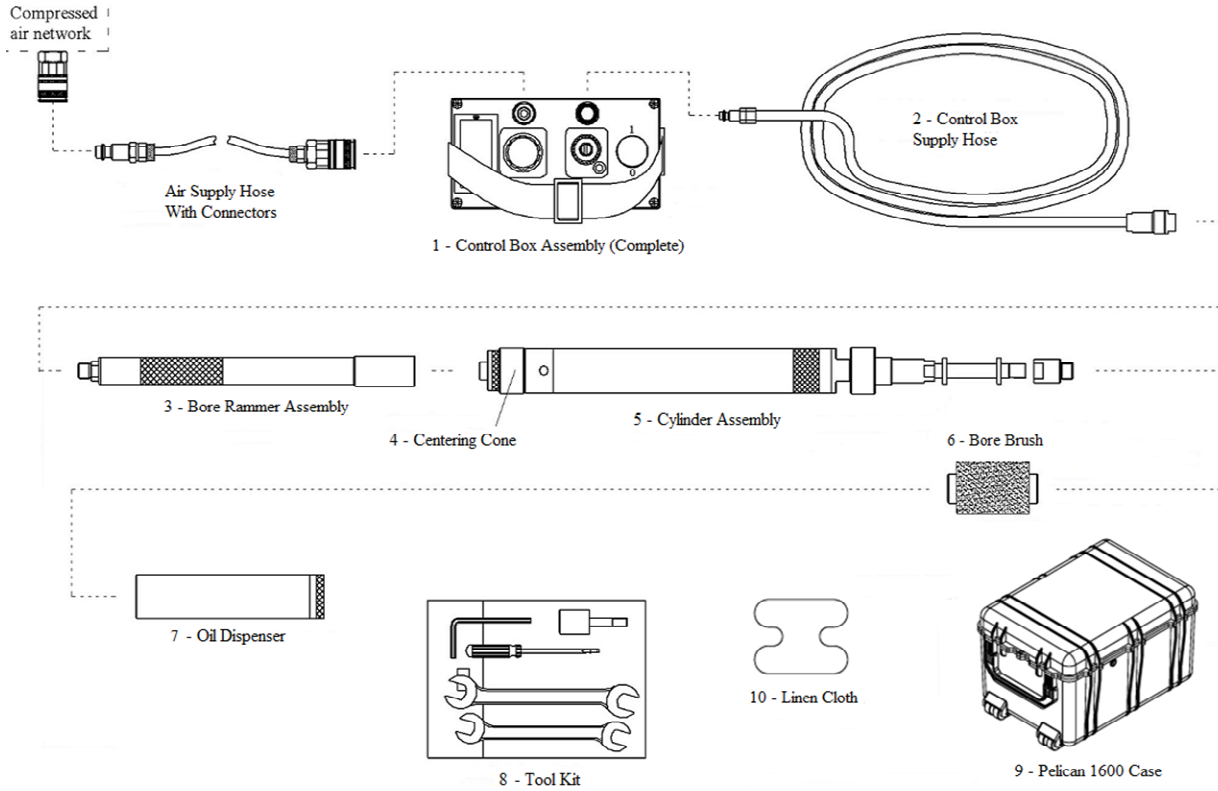

2. OPERATION

If not stated otherwise the following instructions refer to parts or subassemblies described in the pictures above. Proper assembly and disassembly contributes to system effectiveness and longevity of the system as well as unit readiness. This section discusses exactly how the system should be removed, used, and repacked.

WARNING

Make sure proper personal protection equipment is used during operation with the machine.

-Never start the vibrations before the brush is in the bore. When the cylinder is vibrating in the bore just a loose grip for a few seconds with a hand is allowed. No other contact of the vibrating parts with human body is allowed.

-Use recommended oils and materials to insure system operates properly.

2.1 Assembly

- a. Open the Pelican 1600 Case.

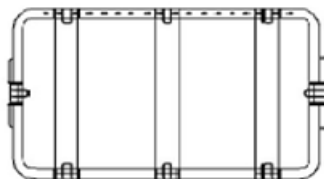

- b. Remove the CBA from the case first and set it next to the weapon or hang it over the barrel of the weapon. (Barrel of weapon should be parallel to the ground +/- 5 degrees). Make sure the control box is not turned on. ON/OFF knob should be in DOWN position.

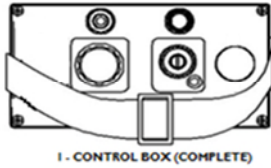

- c. Remove the Control Box Supply Hose from the case. Connect the male quick disconnect hose end to the female quick disconnect coupler on the CBA. Place remaining hose on the ground.

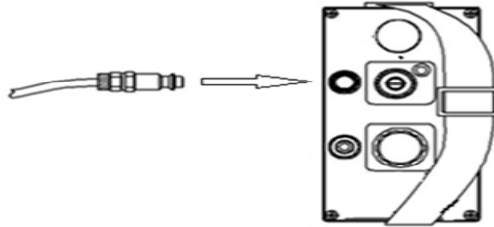

- d. Remove the Cylinder Assembly From the case and apply the Bore Rammer Assembly to it. Screw on the bore rammer in an upright position to avoid damaging the threads.



- e. Apply the Bronze Bore Brush to the end of the Cylinder Assembly and screw on the cap.



- f. Attach the other end of the Control Box Supply Hose to the end of the Cylinder Assembly
- g. Make sure all parts are tightly fastened to each other.

- h. Finally you will attach your air supply to the male quick disconnect on the control box.

NOTE: We recommend a Speedaire 3.0 HP, 230VAC, 20 Gal. Portable Electric Barrel Air Compressor

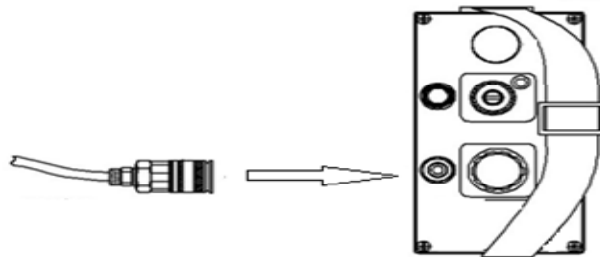

2.2 Operating the System

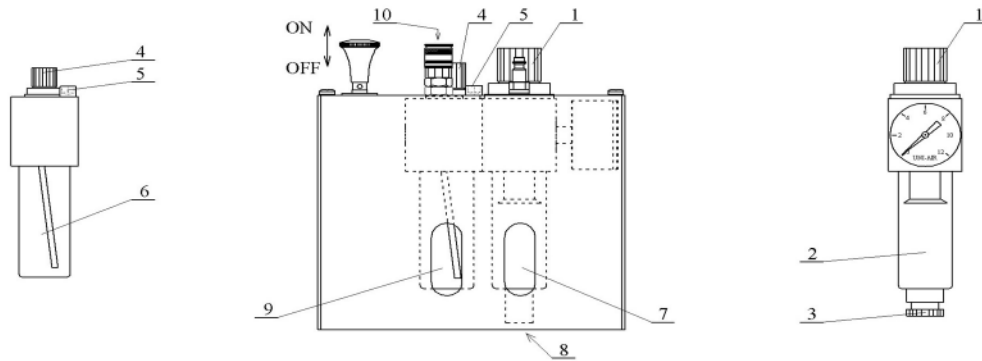

Fig. 1

NOTE: Control box should always be in vertical position.

- Check that the air pressure is between 100-120psi for optimum brush performance (Fig. 1-2). Adjust the knob at the top of regulator to add or release air pressure (Fig. 1-1). Always check the condensed water level in the dehumidifier cup (Fig. 1-7). No liquid should be present. Unscrew the knob at bottom to empty if necessary (Fig. 1-3). To do this, you will have to unscrew the 4 screws at the top of the box and open the Control Box Up.
- Check that the oil levels are between the minimum and the maximum level lines on the glass (Fig. 1-9) of the oil regulator (Fig. 1-6). If oil is low, unscrew cap at top (Fig. 1-5) and put in more oil. There is a funnel in the tool kit to assist with this.

NOTE: We recommend F442 OIL. The amount of air lubrication oil that is atomized into the air is regulated with the knob on top (Fig. 1-4). Rotating the knob clockwise lowers the amount of lubrication oil and rotating counter-clockwise increases. Recommended amount of oil is $1\frac{3}{4}$ turns from totally closed. When the CBA is turned on and air is blowing through the CBSH, a drop of oil should be noticed in the chamber of the FRL every 8 to 10 seconds.

- After Control box has been checked. Pick up the Cylinder Assembly and insert it into the muzzle end of the barrel so that the brush is fully inserted as shown below.

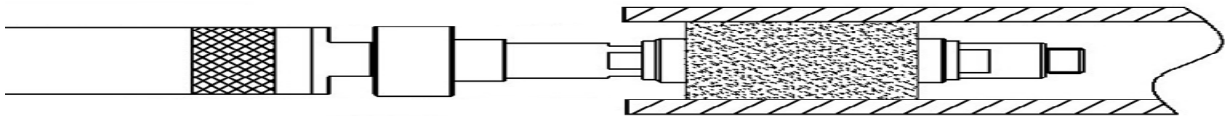

- Pull the knob on the control box upwards to turn system on (Fig. 1).
NOTE: Do not turn on system before brush is inserted into bore. When the cylinder is vibrating in the bore just a loose grip for a few seconds with a hand is allowed. Prolonged contact with your person may result in injury.
- Let the system run down the barrel of the weapon system, guiding the hose as it moves automatically.
- Once it reaches the chamber, you will feel the system stop. Pull quickly on the hose and maintain pressure until it reverses the direction of the system. Again, just guide the hose out as it automatically comes back towards you.
- Push down on the ON/OFF knob when the brush returns to the end of the barrel to turn the system off.

Repeat procedure 2.2 [c. - g.] as many times as needed to clean the majority of the debris out of the barrel

2.3 Oiling the Barrel

NOTE: You will want to change to the **Abrasive Nylon Brush** (gray bristles) for this procedure. To do this, Remove the Brush Fastening Screw and follow the procedures used in **2.1[d.]**. Replace the stainless brush with the abrasive brush and retighten the brush fastening screw. Oil dispenser is designed only to spray oils. Pouring other liquids into the dispenser could damage the dispenser.

- a. Once you have applied the Abrasive Nylon Brush you will then add the oiler to the cylinder assembly.
- b. Remove the Oiler from the Pelican Case. It will be kept in a vessel for safe keeping and to prevent oil leakage after use. You will have to unscrew it from the vessel.

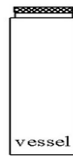

- c. Screw the Oiler into the end of the Brush Fastening Screw at the end of the cylinder assembly. System will look like below.

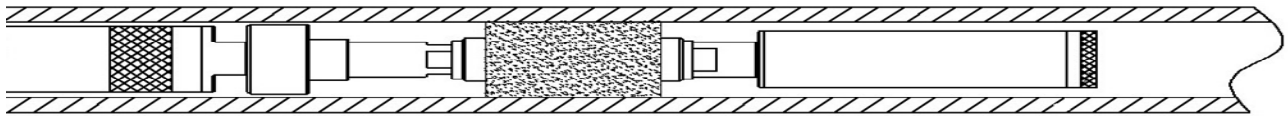

- d. Follow the same steps in **2.2 [c. - g.]** with the oiler attached to perform the oiling of the barrel. Oiler sprays the bore surface with oil while the assembly is vibrating through the bore.
- e. Repeat as many times as desired. A couple passes should be sufficient enough but it does depend on how dirty the barrel was.
- f. Once finished, remove the oiler and place it back in the vessel to be put back in the case.

2.4 Finish Cleaning With the Sleeve

NOTE: You will want to change to the **Nylon Brush** (black bristles) for this procedure. To do this, Remove the Brush Fastening Screw and follow the procedures used in **2.1[d.]**. Replace the abrasive nylon brush with the nylon brush and retighten the brush fastening screw.

- a. The sleeve is mounted on the brush. Wrap the middle piece around the bore brush starting with the tethered end so that it gets covered up once the remaining cloth comes back around. (If you have the sleeve liners, just stretch and pull over the brush until it covers all the bristles.)
- b.

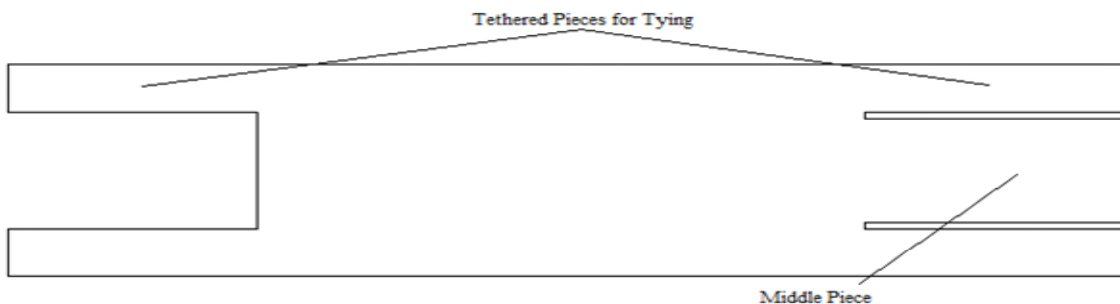

- c. Use the smaller tethered pieces at the top and bottom of the linen to create a knot to hold the sleeve onto the bore brush.
- d. There are no special requirements about the sleeves that should be used for barrel cleaning, but the optimum performance is guaranteed only with the original sleeves. Other sleeves might damage the design of the brush ring. The sleeve must be mounted on the brush ring firmly. The sleeve must not be too large. This might jeopardize good movement of the assembly through the bore.
- e. Complete assembly is now ready to be placed inside the bore. Repeat steps in 2.2 [c. - g.] to perform the cleaning again. The sleeve wipes the bore surface while the assembly is vibrating through the bore.
- f. Repeat as many times as needed.

3. Complete Cylinder Assembly/Disassembly

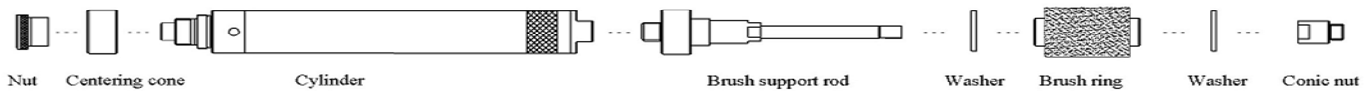

- Centering cone replacement:

Centering cone is screwed on the Cylinder with the Nut. The Nut is tightened with bare hand.

- Brush ring replacement:

Brush ring is replaced using 16/17 and 18/19 open end wrenches that are parts of the Tool kit. Brush support rod, with Front plastic slide mounted, is not unscrewed from the Cylinder for this action. Brush ring is tightened onto the Brush support rod with suitable wrenches.

4. Complete Oiler Assembly/Disassembly

- In case oil is not sprayed out of the Oil dispenser, the dispenser has to be disassembled. The Oil dispenser assembly is presented below.

- Remove the Oil dispenser closing cap by unscrewing it. Remove the Oil suction tube subassembly. Clean precisely all the parts of this subassembly with compressed air. Make sure that all air and oil paths are opened. The amount of oil that is sprayed out of the dispenser is controlled with the screw found on the Counter weight. Rotating the screw clockwise with the screwdriver reduces the amount of oil and rotating counter-clockwise increases the amount of oil. Make sure that the Oil suction tube subassembly is placed back into the container properly. Make sure that the Central tube is oriented properly.

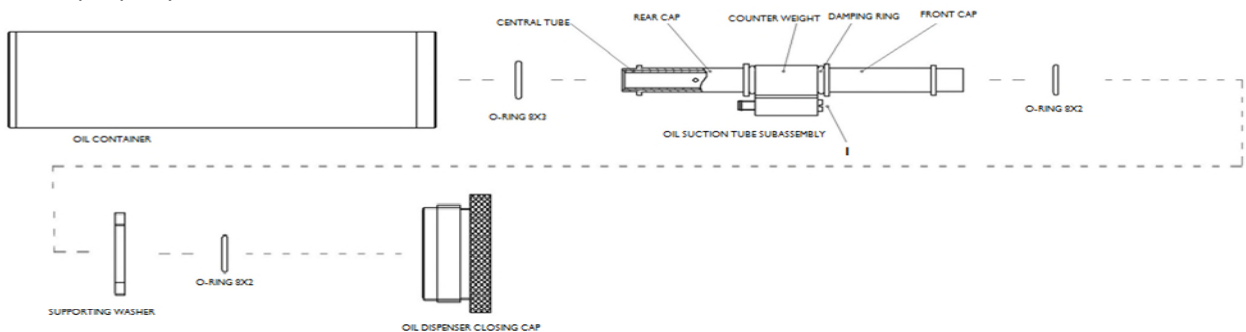

5. Tool Kit

Integral part of the OCS is also The Tool Kit. Tools in the kit shown below are used for small repairs and OCS everyday use.

- OCS-TKB-001 - Tool kit bag
- 5420A27 - Open end wrench 18/19, Tightening of couplings, brush rings.
- 5420A22 - Open end wrench 16/17, Tightening of couplings, brush rings.
- 4383T1 – Funnel, Air lubrication unit oil refilling.
- 7122A47 – Hex Key 3/16” tighten and untighten screws on control box top
- 6958A14 – Hex Key 4mm, tighten and untighten screw for oiler filter regulator
- 5682A75 – Screwdriver, 3/16” x 7-3/4” Oil dispenser adjustments, Foam dispenser adjustments, air lubrication unit adjustments.

Note: On special request of the customer some other items could be added to the Tool kit.

6. TROUBLESHOOTING

WARNING

In the case of any problem or malfunction, an unauthorised person should not try to repair or change the machine. Make sure proper personal protection equipment is used during repair in maintenance procedures. If not stated otherwise, power source should be disconnected from the machine during troubleshooting, repair and maintenance procedures. In case operator has any doubts regarding proper function of the machine or its components authorised person should be informed about the problem.

In case the system is not working properly please follow the following instructions. For more detailed instructions please read carefully complete Use and Maintenance Manual. **The operator of the described equipment should be familiar with the complete content of this Use and Maintenance Manual.**

WARNING

Never start the vibrations before the brush is in the bore. When the cylinder is vibrating in the bore just a loose grip for a few seconds with a hand is allowed. No other contact of the vibrating parts with the human body is allowed.

6.1 Air leaks

When audible air leaks are heard follow the following steps:

- Push the switch on the Control box to OFF position.
- Connect the Air supply hose to the Control box.
- Pull the switch on the Control box to ON position.
- Detect air leak. Inform an authorized person about the problem.

6.2 Hose connection

- **Air supply hose with connectors – (not included with kit)**
- **CBSH with connectors – OCS-CBSH-001**

When connection of air hoses with quick couplings are impossible or air leaks are noticed follow the following steps:

- Pull the sleeve of the coupling.
- Connect the coupling.
- Detect the damage on the coupling or coupling plug. Inform an authorized person about the problem.

6.3 Control Box Assembly – OCS-CBA-001

Pressure gauge

Optimal regulated pressure for cleaning procedure is 100-120 psi. In case you have difficulties adjusting the pressure follow the following steps:

- Make sure you connect pressurized air.
- Adjust pressure to 120 psi.
- In case rotating the pressure regulating knob results in no response on the pressure gauge inform an authorised person about the problem.

Air lubrication

In case you notice problem with air lubrication follow the following steps:

- Try to adjust the amount of oil added to air stream on air lubrication unit.
- In case adjustment of the air lubrication unit results in no air lubrication inform an authorized person about the problem.

Air leak

In case you notice air leak in the Control box follow the following steps:

- Try to detect the air leak.
- In case the air leak is caused due to loosening of some connection, repair the connection.
- In case part from the Control box assembly has been damaged inform an authorized person about the problem.

6.4 Cylinder Assembly – OCS-CYL-040-057

In case cylinder assembly does not produce sufficient or no vibrations follow the following steps:

- Connect pressurized air to the Control box using the Air supply hose.
- Check pressure gauge on the Control box. Optimal pressure is 100-120 psi.
- Connect the CBSH to the CBA.
- Pull the switch on the Control box to ON position. Strong air blast should be heard and felt. In case there is no air blast noticed from the CBSH, refer to section **6.2 and 6.3 Troubleshooting - topics about Control box and Hoses.**
- Push the switch on the CBA to OFF position.
- Apply fast jerky movement on the cylinder. Piston movement inside the cylinder should be felt and heard. If the piston does not move inside the cylinder inform an authorized person about the problem.
- Connect the CBSH to the cylinder assembly.
- Pull the switch on the Control box to ON position. In case only air is blown through the cylinder and no vibrations are produced inform an authorised person about the problem.

6.5 Oil Dispenser

In case oil is not sprayed out of the Oil dispenser follow the following steps:

- Adjust the jet that controls the amount of oil sprayed out of the dispenser.
- Disassemble the Oil dispenser and clean precisely all the parts.
- In case some part is damaged inform an authorised person about the problem.

6.6 Cylinder assembly does not move through the bore

In case cylinder assembly is not moving through the bore follow the following steps:

- Make sure the cylinder produces vibrations. In case the cylinder produces no vibrations refer to section **6.4 Troubleshooting - topics about Cylinder assembly.**
- In case the cylinder produces vibrations, but assembly is not moving through the bore replace non suitable brush ring.
- Check the brushes themselves to make sure they are not too worn out.

6.7 Cylinder assembly does not clean the barrel properly

In case cylinder assembly is not cleaning the barrel properly follow the following steps:

- Make sure the cylinder produces vibrations. In case the cylinder produces no vibrations refer to section **6.4 Troubleshooting - topics about Cylinder assembly**
- In case the cylinder produces vibrations, but assembly does not clean the chamber properly, replace non suitable brush ring.
- Check for correct brush size and check if brush is too worn out.

7. Storage

- Clean precisely all parts of the machine with damp sleeve after each use. Use non aggressive cleaning agent. Aggressive bore cleaning agent could damage painted surfaces of the machine in case not removed.
- When transporting and storing the machine make sure the surrounding temperature remains included between -31°F and +149°F.
- If the need arises to store the machine for longer period of time, make sure the humidity values in the storage area remain included between 30 and 80%.
- No special actions are required for placing the equipment into storage.
- No special actions are required for removing the equipment from storage. Functional test should be carried out before using the equipment for the first time after longer period of storage.

8. ACRONYMS

ASHC	Air Supply Hose w/Connectors (not included with kit)
BBRA	Bore Brush Abrasive
BBRN	Bore Brush Nylon
BBRS	Bore Brush Stainless Steel
BFS	Brush Fastening Screw
BRA	Bore Rammer Assembly
BRS	Brush Ring Spacer
CBA	Control Box Assembly
CBRA	Chamber Brush Abrasive
CBRN	Chamber Brush Nylon
CBRS	Chamber Brush Stainless Steel
CBS	Chamber Brush Screw Assembly
CBSH	Control Box Supply Hose
CCK	Centering Cone
CRA	Chamber Rammer Assembly
FDA	Foam Dispenser Assembly
FRL	Filter Regulator Lubricator
OCS	Ordnance Cleaning System
OIL	Oil Dispenser Assembly
TKA	Tool Kit Assembly
CYL	Cylinder Assembly
SRA	Short Rammer Assembly

CAS	Pelican Case
CBFS	Chamber Brush Fastening Screw
CBE	Chamber Brush Extension